

Propane Powered Industrial Truck Inspection Form

Vehicle Type & ID. _____

Note: All forklifts must be inspected before use each shift. The operator has the responsibility to make sure that the forklift has been inspected and the inspection has been recorded and the inspection sheets saved. Report any problems to your supervisor and do not attempt any repairs.

- Fuel tank not dented, damaged and not leaking.
- Fuel tank is secured to the tank mount.
- Hoses are connected properly, not damaged and not leaking.
- Tires are in good shape and are of the proper size.
- The horn works.
- All of the lights work.
- No fluid leaks.
- The oil and water levels are OK.
- The seat belts are in good shape.
- The forks and its accessories are in good working order.
- The chains are good shape and they have the same tension.
- The fire extinguisher is inspected monthly and is in good condition.
- The brakes are in good order. They hold the forklift.
- The steering is in good order.

Notes: _____

Inspector: _____ **Date:** _____ **Shift:** _____

Electric Industrial Truck Inspection Form

Vehicle Type & ID. _____

Note: All forklifts must be inspected before use each shift. The operator has the responsibility to make sure that the forklift has been inspected and the inspection has been recorded and the inspection sheets saved. Report any problems to your supervisor and do not attempt any repairs.

- Battery electrolyte levels are full. Fill only with distilled water.
- Batteries have a full charge.
- Battery cables are in good shape and there is no corrosion on the terminals.
- Tires are in good shape and are of the proper size.
- The horn works.
- All of the lights work.
- No hydraulic fluid leaks.
- The seat belts are in good shape.
- The forks and its accessories are in good working order.
- The chains are good shape and they have the same tension.
- The fire extinguisher is inspected monthly and is in good condition.
- The brakes are in good order. They hold the forklift.
- The steering is in good order.

Notes:

Inspector: _____ **Date:** _____ **Shift:** _____

Gasoline Industrial Truck Inspection Form

Vehicle Type & ID. _____

Note: All forklifts must be inspected before use each shift. The operator has the responsibility to make sure that the forklift has been inspected and the inspection has been recorded and the inspection sheets saved. Report any problems to your supervisor and do not attempt any repairs.

- Fuel tank is full and the cap is on the tank.
- No fuel leaks or spills.
- Tires are in good shape and are of the proper size.
- The horn works.
- All of the lights work.
- No fluid leaks.
- The oil and water levels are OK.
- The seat belts are in good shape.
- The forks and its accessories are in good working order.
- The chains are good shape and they have the same tension.
- The fire extinguisher is inspected monthly and is in good condition.
- The brakes are in good order. They hold the forklift.
- The steering is in good order.

Notes:

Inspector: _____ **Date:** _____ **Shift:** _____

Diesel Industrial Truck Inspection Form

Vehicle Type & ID. _____

Note: All forklifts must be inspected before use each shift. The operator has the responsibility to make sure that the forklift has been inspected and the inspection has been recorded and the inspection sheets saved. Report any problems to your supervisor and do not attempt any repairs.

- Fuel tank is full and the cap is on the tank.
- No fuel leaks or spills.
- Tires are in good shape and are of the proper size.
- The horn works.
- All of the lights work.
- No fluid leaks.
- The oil and water levels are OK.
- The seat belts are in good shape.
- The forks and its accessories are in good working order.
- The chains are good shape and they have the same tension.
- The fire extinguisher is inspected monthly and is in good condition.
- The brakes are in good order. They hold the forklift.
- The steering is in good order.

Notes:

Inspector: _____ **Date:** _____ **Shift:** _____

INDUSTRIAL VEHICLES

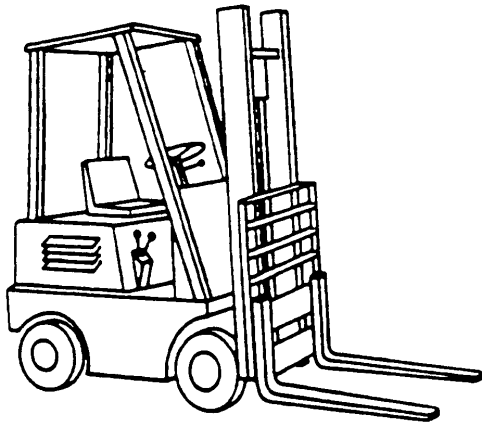

- High Lift Truck
- Counterbalanced Truck
- Cantilever Truck
- Rider Truck
- Fork Lift Truck

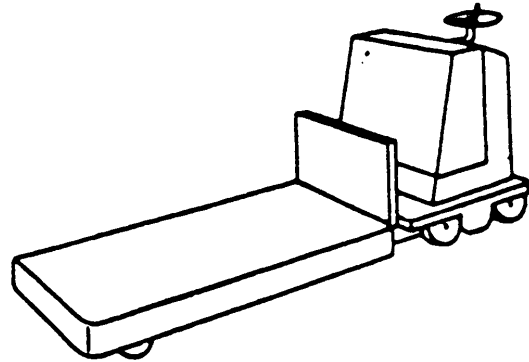

- Low Lift Truck
- Low Lift Platform Truck

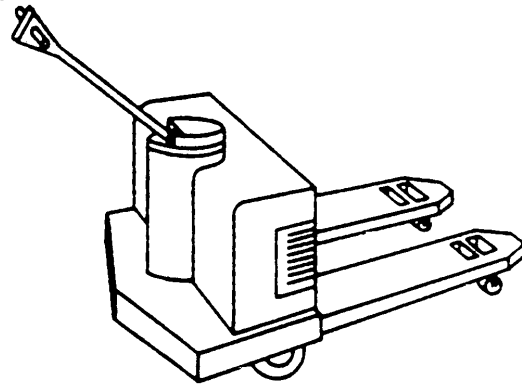

- Motorized Hand Truck
- Pallet Truck

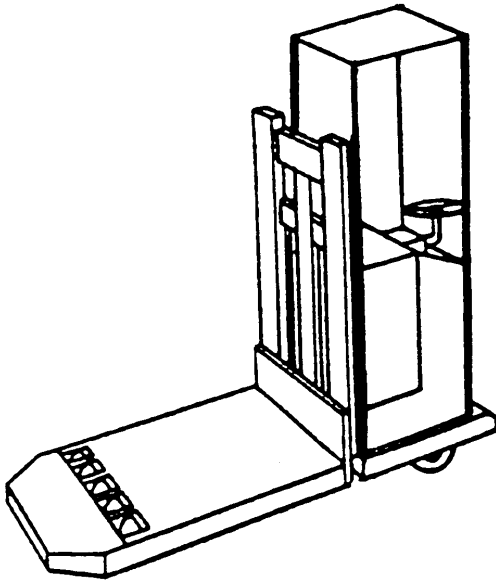

- High Lift Truck
- High Lift Platform Truck

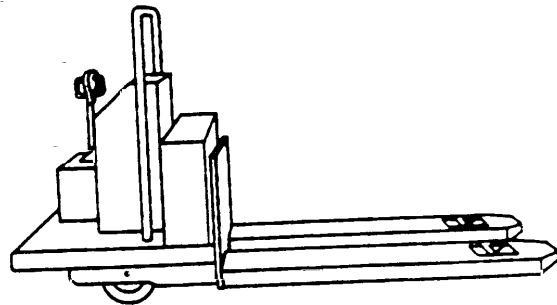

- Motorized Hand/Rider Truck

INDUSTRIAL VEHICLES

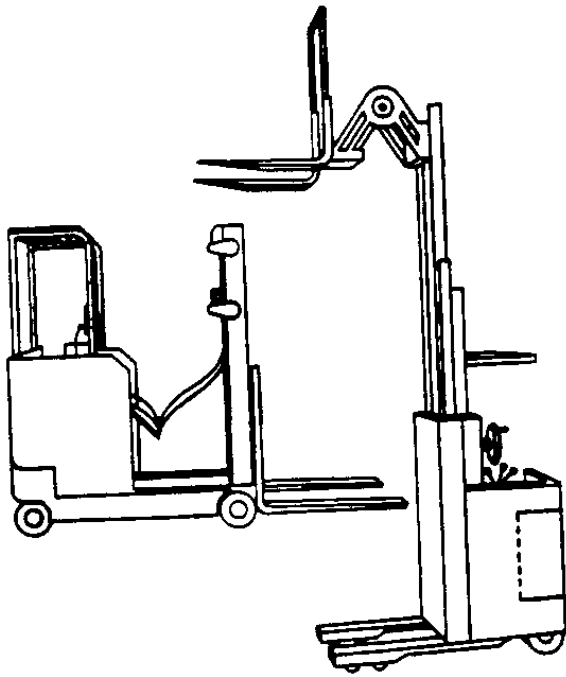

—Reach Rider Trucks

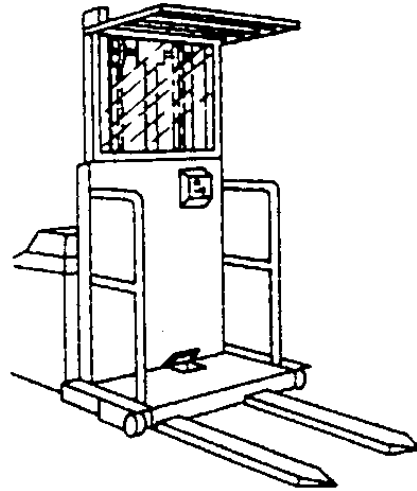

—Order Picker High Lift Rider Truck

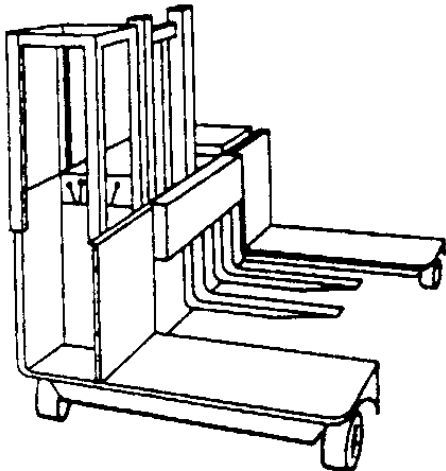

—Single Side-Loader Rider Truck

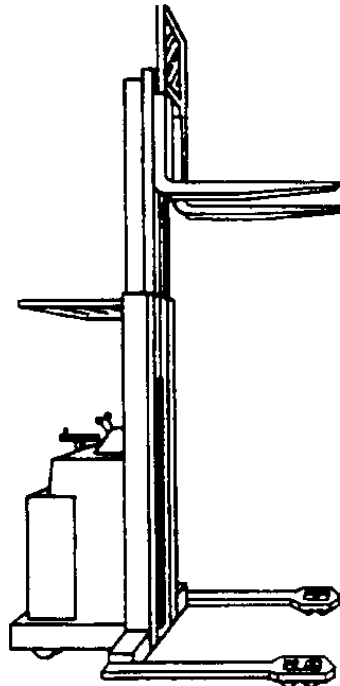

—Narrow Aisle Rider Truck
—Straddle Truck